

PISTON TERMINOLOGY

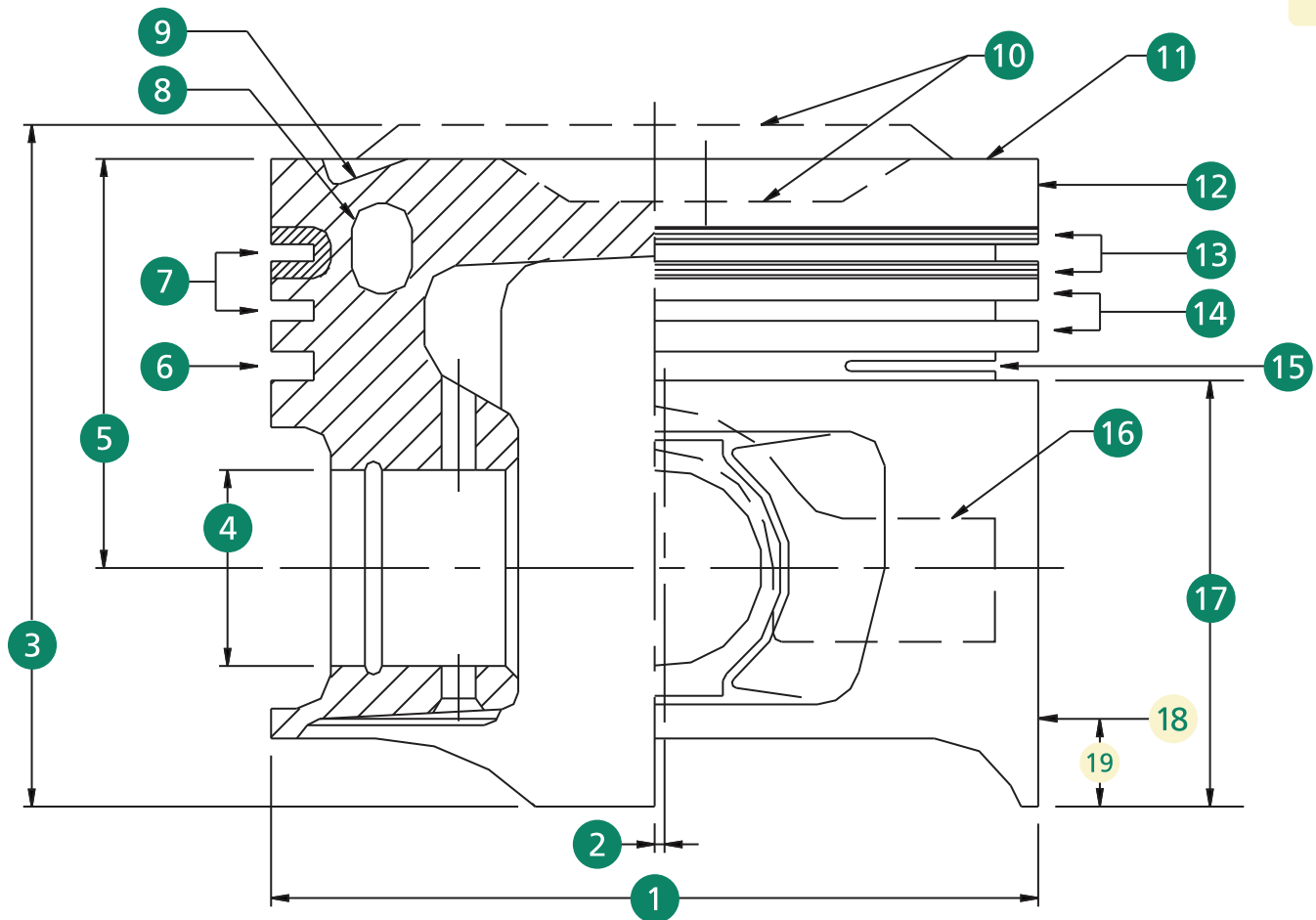

- | | |
|---|---|
| <p>01. PISTON SKIRT DIAMETER</p> <p>02. ECCENTRICITY OF PIN AXIS AGAINST PISTON AXIS</p> <p>03. TOTAL PISTON LENGTH</p> <p>04. GUDGEON PIN HOLE DIAMETER</p> <p>05. COMPRESSION HEIGHT</p> <p>06. OIL RING GROOVE</p> <p>07. FIRST AND SECOND COMPRESSION RING GROOVES</p> <p>08. OIL COOLING GALLERY</p> <p>09. VALVE POCKET</p> | <p>10. DEPRESSED COMBUSTION CHAMBER OR RAISED CROWN</p> <p>11. PISTON CROWN</p> <p>12. CROWN LAND</p> <p>13. ALFIN REINFORCEMENT</p> <p>14. RING LAND</p> <p>15. OIL SLIT GROOVE</p> <p>16. HIDDEN STEEL STRUTS</p> <p>17. SKIRT AREA</p> <p>18. POINT OF MRC MEASUREMENT (Minimum Recommended Clearance)</p> <p>19. HEIGHT OF MP (Measuring Point)</p> |
|---|---|



INSTALLATION NOTE

TEIKIN® ENGINE COMPONENTS ARE MANUFACTURED UNDER THE HIGHEST PRECISION STANDARD AND STRICT QUALITY SYSTEM. AS SUCH, TEIKIN® ENGINE COMPONENTS MUST BE HANDLED WITH THE UTMOST OF CARE DURING INSTALLATION.

GENUINE TEIKIN® PISTONS FOR THE AFTERMARKET ARE SUPPLIED COMPLETE WITH GUDGEON PINS AND CIRCLIPS. WE RECOMMEND FULL AND COMPLETE ENGINE SET REPLACEMENT OF PISTONS, PINS AND CIRCLIPS FOR ALL CYLINDERS.

TEIKIN® PISTONS IN A BOX SET ARE GRADED ACCORDING TO THE APPROPRIATE FIT. HENCE WE RECOMMEND USING THE FULL SET IN THE BOX.

PISTON CROWNS ARE MARKED WITH THE APPROPRIATE SIZE AND INSTALLATION DIRECTION. SUCH MARKINGS ARE TO BE OBSERVED AND FOLLOWED ACCORDINGLY.

MINIMUM RECOMMENDED CLEARANCE (MRC) VALUE BETWEEN PISTON SKIRT & CYLINDER LINER/BORE WALL AND PISTON SKIRT DIAMETER MEASURING POINT (MP) LOCATION FOR EACH ENGINE IS PROVIDED IN THIS CATALOG.

INSTALLATION OF POWER-UP / TURBO CHARGER / TURBO CONVERSION KIT ONTO AN ORIGINALLY NON-TURBO ENGINE IS NOT RECOMMENDED.

PISTON RINGS MUST BE ASSEMBLED AND FITTED CORRECTLY ONTO THE PISTON. EXCESSIVE FORCE DURING THEIR REMOVAL AND FITTING WILL CAUSE PERMANENT DEFORMATION TO THE RINGS AND IMPAIR THEIR SEALING PERFORMANCE. THE RING GAPS MUST BE DISTRIBUTED EVENLY AROUND THE CIRCUMFERENCE OF THE PISTON.

CIRCLIPS MUST BE FITTED WITH THEIR GAPS FACING TOWARD THE BOTTOM SIDE OF THE GUDGEON PIN HOLES.

CYLINDER LINERS / BORES MUST BE CLEANED AND INSPECTED FOR DAMAGES AND CORROSION. CORRODED AND DAMAGED SURFACES MUST BE REMOVED BY REBORING AND INSTALLING OVERSIZED LINERS IF NECESSARY.

LINER FLANGES' SEATS IN THE BORE MUST BE CLEANED, PROPERLY CHAMFERED AND PERPENDICULAR TO THE BORE AXIS. INCORRECT SEATS WILL CAUSE BREAKAGE TO FLANGES AND CAUSE MAJOR DAMAGE TO THE ENGINE.

CONNECTING RODS MUST BE CHECKED FOR PARALLELISM & DISTORTION AND RE-ALIGNED AS NECESSARY.

ALL COMPONENTS IN THE ENGINE MUST BE THOROUGHLY LUBRICATED AND CLEANED FROM DIRT, MACHINING RESIDUES AND FOREIGN MATTERS BEFORE ENGINE ASSEMBLY.

CYLINDER HEAD BOLTS ARE TO BE TIGHTENED TO THE TORQUE AND ROTATION ANGLE SPECIFIED BY THE ENGINE MAKER.

IN DIESEL ENGINES, INJECTION PUMP TIMING AND SETTING MUST BE SET AS PER THE FACTORY STANDARD.

USE OF AEROSOL STARTING AID IS TO BE AVOIDED.

ENGINE COOLING AND LUBRICATION SYSTEM MUST BE CAREFULLY CHECKED BEFORE IGNITING THE ENGINE.

